



ELTEK VALERE
always on

STATIC TRANSFER SWITCH

STS207

USER MANUAL



UM_STS207_WEB_E_R1.3



Notes to this manual

ATTENTION! Read this manual carefully before installing and commissioning the specified module. This manual is a part of the delivered module. Familiarity with the contents of this manual is required for installing and operating the specified module. The function description in this manual corresponds to the stage of technology at the date of publishing. Technical changes and changes in form and content can be made at any time by the manufacturer without notice. There are no obligations to update the manual continually. The rules for prevention of accidents for the specific country and the general safety rules in accordance with IEC 364 must be observed. The module is manufactured in accordance with applicable DIN and VDE standards such as VDE 0106 (part 100) and VDE 0100 (part 410). The CE marking on the module confirms compliance with EU standards 2006-95-EG (low voltage) and 89/339 EWG (electromagnetic compatibility) if the installation and operation instructions are followed.

Supplier:

	ELTEK VALERE INDUSTRIAL GmbH Schillerstraße 16 D-32052 Herford
	+ 49 (0) 5221 1708-210
FAX	+ 49 (0) 5221 1708-222
Email	Info.industrial@eltekvalere.com
Internet	http://www.eltekvalere-industrial.com

© Copyright ELTEK VALERE INDUSTRIAL 2008. All rights reserved.

Please note: Repetition, copying and /or taking possession of this operation and maintenance manual, even in extracts, with electronic or mechanical means, requires the written prior permission of the manufacturer.

Static Transfer Switch STS207

User Manual
Page 3 (28)

The current revision status of this manual is the following:

Revision: 1.3

Date: 2008-10-28

Revision	Description of change	Writer	Date
00	Preliminary first edition	RTH	2007-10-25
01	First edition	RTH	2008-05-07
02	Minor text modifications, screenshot "Net Connection" updated, section "Trouble Shooting" completed	RTH	2008-07-18
1.3	Minor text modifications, new revision numbering (X.X) introduced	RTH	2008-10-28

Table of contents

1. Safety Instructions and Waste Disposal Rules	6
2. General Information	7
2.1 Example of use	7
2.2 Operating modes.....	8
2.2.1 Inverter priority configuration.....	8
2.2.2 Mains priority configuration	8
3. Type Range/ Main Data.....	8
3.1 Main output data.....	8
3.2 Optional equipment for STS assembly:	9
3.3 Front view: operating elements, indicators.....	10
3.4 Electrical connections.....	11
3.4.1 Pin assignment of the rear side connector:	11
3.4.2 Pin assignment of the front side CAN-Bus connector (RJ11):.....	12
3.4.3 Pin assignment of the front side Ethernet connector (RJ45):.....	12
3.5 Cooling/Air flow direction	13
3.6 Communication interfaces	13
3.6.1 CAN-Bus.....	13
3.6.2 Ethernet (Net Connection).....	14
4. Handling	15
4.1 Storage	15
4.2 Commissioning.....	15
4.3 Operation.....	15
4.3.1 LED Indications.....	16
4.3.2 Adjustment keys	16
4.3.3 LC-Display: Indication of measured values and alarm messages	17
5. Parameter adjustment / Menu structure.....	18
5.1 Adjustable Parameters (Customer menu)	18
5.2 Structure of the customer menu.....	19
6. Maintenance	21
7. Trouble shooting.....	21
8. Technical specifications	23
8.1 Dimensional drawings	25
9. Notes	26

Index of Figures

Figure 1. Block diagram “Example of use”7

Figure 2. AC Rack ACR INV222-6.759

Figure 3. Front view 10

Figure 4. Rear side connector 11

Figure 5. Front side CAN-Bus connector 12

Figure 6. Front side Ethernet connector 12

Figure 7. Module air flow 13

Figure 8. Sample screenshot 14

Figure 9. LC-Display: Indication of measured values 17

Figure 10. Structure of the customer menu 19

Figure 11. Continuation of the customer menu 20

Figure 12. Display “Alarm Messages” 21

Figure 13. Module dimensions 25

1. Safety Instructions and Waste Disposal Rules



Warning!

Because several components of operating electrical modules are charged by dangerous voltage, the improper handling of electrical modules may be the cause of accidents involving electrocution, injury, or material damages.

- Operation and maintenance of electrical modules must be performed by qualified skilled personnel such as electricians in accordance with EN 50110-1 or IEC 60950.
- Install the module only in areas with limited access to unskilled personnel.
- Before starting work, the electrical module must be disconnected from mains. Make sure that the module is earthed.
- Do not touch connector pins as they can be charged with dangerous voltage up to 30 seconds after disconnection.
- Only spare parts approved by the manufacturer must be used.

All electric modules must be disposed of separate from domestic waste at collecting points that have been set up by the government or municipal authority.

“Separate collection is the precondition to ensure specific treatment and recycling of WEEE and is necessary to achieve the chosen level of protection of human health and the environment in the Community.”

The above statement from EU directive 2002/96/EC applies to all electric modules installed within EU countries.

In countries outside the EU, different rules may apply regarding waste disposal of electric modules.

For more information about waste disposal of your discarded equipment, contact your ELTEK VALERE INDUSTRIAL partner.

2. General Information

The static transfer switch STS207 is designed for a nominal switching capacity of 7kVA and is used for nearly interruption free switching (<4 ms) between two AC sources (usually inverter and substitute-mains supply). It is intended for the operation with inverters of series INV215/222. Consequently AC consumers can be driven nearly without interruption if one of the two power sources fails.

The STS207 is a hot plug-in module with rear side connectors and is designed to be mounted in an assembly set sub rack (see section 3.2).

The operation and indication elements as well as an Ethernet and a CAN-Bus connector are user-friendly integrated in the front plate of the unit.

2.1 Example of use

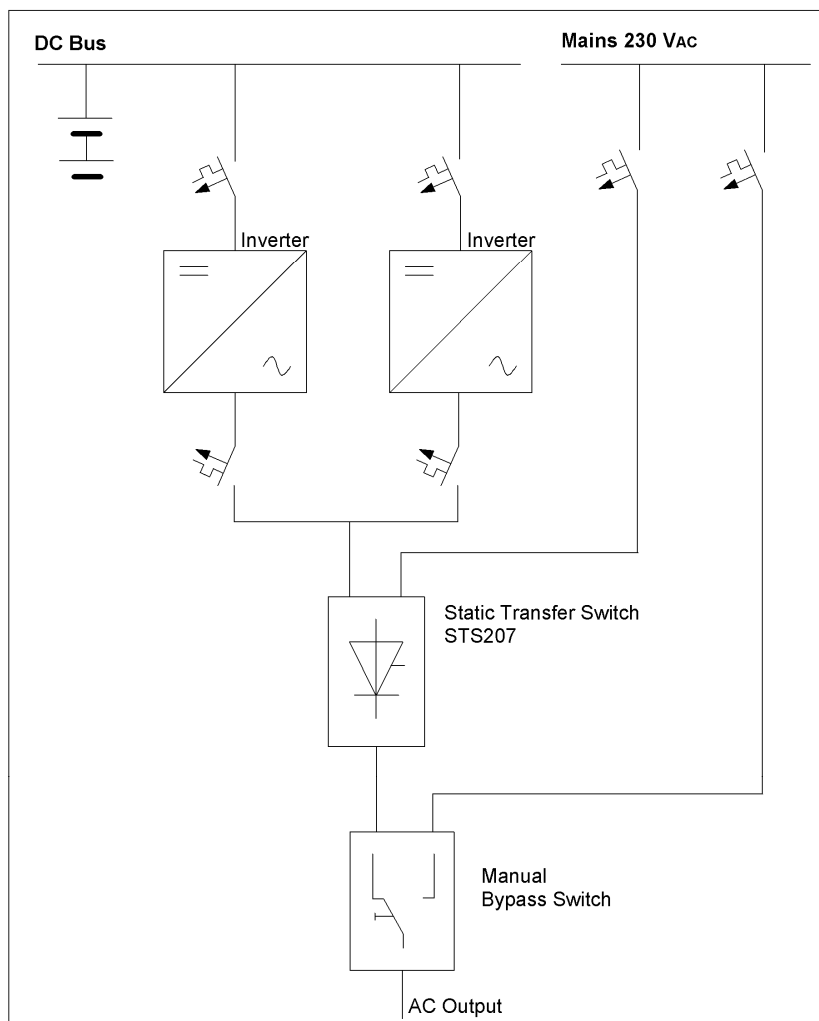

Figure 1. Block diagram "Example of use"

2.2 Operating modes

The static transfer switch STS is designed for the operating modes “inverter priority” and “mains priority”. The consumer load is energized by the priority source if the operating system works under fully functional conditions.

2.2.1 Inverter priority configuration

In the operating mode “inverter priority” the load is switched on inverters during normal operation. This is the standard configuration (factory setting). Source “Mains” only is required to energize the consumer load if source “Inverter” fails or is overloaded (i. e. distortions by short circuit behaviour or overload). The priority source is programmable via the service menu.

2.2.2 Mains priority configuration

In the operating mode “mains priority” the AC mains works as priority source and the inverter (as “substitute mains”) as source 2.

3. Type Range/ Main Data

Type Designation	Article Code	Nominal Input	Nominal Input Frequency	Redundant Circuitry Supply
STS207-230/230HV	601-070-715.00	230V _{AC}	50 Hz/ 60Hz (adjustable)	91.8-275V _{DC} (high voltage version)
STS207-230/230LV	601-070-515.00	230V _{AC}	50 Hz/ 60Hz (adjustable)	38-75V _{DC} (low voltage version)
STS207-230/230-24V	601-070-415.00	230V _{AC}	50 Hz/ 60Hz (adjustable)	19-45V _{DC} (24V version)

3.1 Main output data

Nominal output voltage: 230V_{AC}
Nominal output current: 30.4A_{AC}
Nominal switching capacity: 7kVA
Output frequency: according to the input frequency

For more specific data, see section 8.

3.2 Optional equipment for STS assembly:

- AC Rack ACR INV222-6.75 LV (assembly set 19" sub rack 2U for max. three inverters INV215-24, INV222-48 or INV222-60 and for one static transfer switch STS207-24V or STS207LV including a wired backplane): Material code= 502-222-315.LV
- AC Rack ACR INV222-6.75 HV (assembly set 19" sub rack 2U for max. three inverters INV222-110 or INV222-220 and for one static transfer switch STS207HV including a wired backplane): Material code= 502-222-315.HV



Figure 2. AC Rack ACR INV222-6.75 fully equipped with three inverters INV222 and one static transfer switch STS207

3.3 Front view: operating elements, indicators

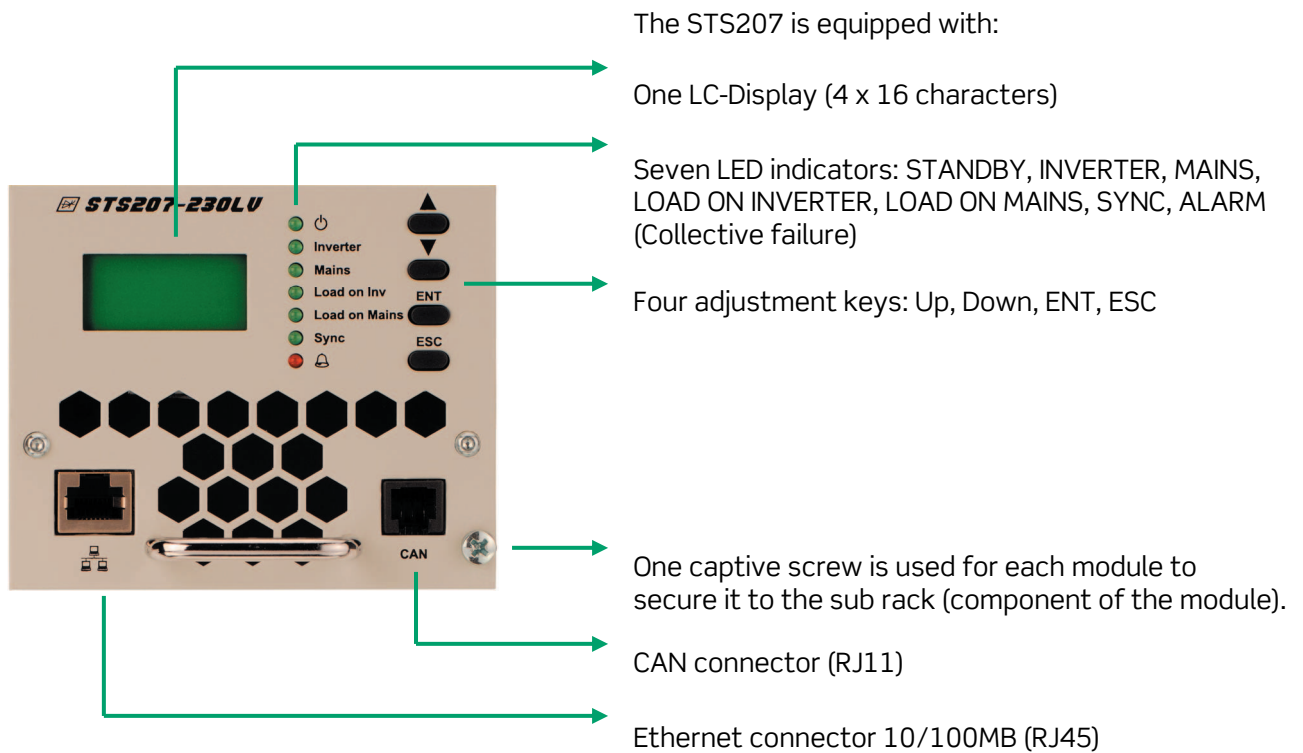

Figure 3. Front view

For more information about the operating elements, LED indicators, LC-Display and front connectors, see the following sections.

3.4 Electrical connections

The STS207 is equipped with:

- 1 rear side connector for: AC input 1 (inverter), AC input 2 (mains), AC output and signalling
- 1 front side connector RJ11 (additional CAN-Bus connector)
- 1 front side connector RJ45 (Ethernet 10/100MB)

3.4.1 Pin assignment of the rear side connector:

Pin	Designation
2b	AC-Input 1 (Inverter)/Phase L1
5b	STS-Output / Phase L1
8b	AC-Input 2 (Mains)/Phase L1
11b	Common Neutral Conductor
16a	CAN_L Signal (low)
17a	CAN_V+ DC-Supply +8...15V
18a	-
19a	Synchronization / SYNC - STAT 2
20a	-
16b	CAN_V- DC-Supply GND
17b	CAN_H Signal (high)
18b	Synchronization / SYNC - STAT 1
19b	Synchronization / SYNC - SIG 2
20b	-
16c	Alarm relay output, NO
17c	Alarm relay output, COM
18c	Synchronization / SYNC - GND
19c	Synchronization / SYNC - SIG 1
20c	-
28b	+Vi (DC-Power Supply*)
31b	-Vi (DC-Power Supply*)

* STS207HV: Vi = 91.8-275V_{DC}
 STS207LV: Vi = 38-75V_{DC}
 STS207LV: Vi = 19-45V_{DC}

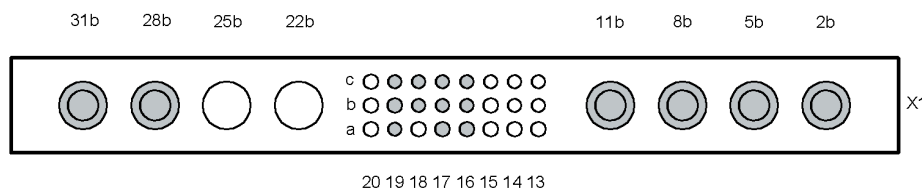

Figure 4. Rear side connector (shown from the rear side of the module)

3.4.2 Pin assignment of the front side CAN-Bus connector (RJ11):

Pin	Signals CAN	Designation
1	CAN_V+	DC-Supply +8...15V
2	CAN_V+	DC-Supply +8...15V
3	CAN_H	Signal (high)
4	CAN_L	Signal (low)
5	CAN_V-	DC-Supply Ground
6	CAN_V-	DC-Supply Ground

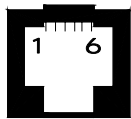

Figure 5. Front side CAN-Bus connector
(socket outlet RJ11, 6-pole)

3.4.3 Pin assignment of the front side Ethernet connector (RJ45):

Pin	Name	Designation
1	TX+	Tranceive Data +
2	TX-	Tranceive Data -
3	RX+	Receive Data +
4	n/c	Not used
5	n/c	Not used
6	RX-	Receive Data -
7	n/c	Not used
8	n/c	Not used

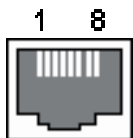

Figure 6. Front side Ethernet connector
(socket outlet RJ45, 8-pole)

3.5 Cooling/Air flow direction

The unit is cooled with an internal fan. The airflow is from the front to rear side. The fan is monitored and speed controlled dependent on module temperature. To provide sufficient air flow, a minimum space (see item "A" in figure 7) of 50mm is required between the unit and the rear cabinet wall as well as an unobstructed supply of air to the front of the module.

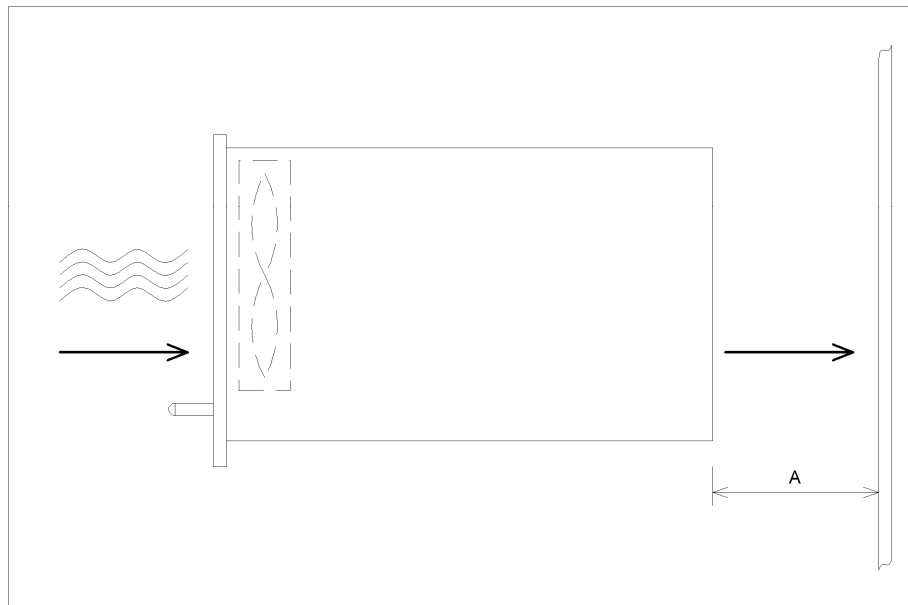

Figure 7. Module air flow

3.6 Communication interfaces

3.6.1 CAN-Bus

The STS207 is equipped with a serial data interface in accordance with the Controller Area Network (CAN) specification. The CAN-Bus connection is integrated in the rear side connector and an additional one is located in the front panel.

Via CAN-Bus the communication of the STS207 with the connected inverters and a possibly implemented UPC3 DC controller unit takes place.

The following information is available via the CAN:

- Status information of the STS207:
 - Availability of the connected inverters
 - Availability of the substitute mains
 - Load on mains/inverter
 - Synchronization
 - Vbatt </>
 - Vout </>
 - Iout >
- Output current of the STS
- Battery voltage connected to the STS
- Inverter and mains voltage
- Inverter and mains frequency
- STS module temperature

Static Transfer Switch STS207

User Manual
Page 14 (28)

3.6.2 Ethernet (Net Connection)

Furthermore the STS207 is fitted with a front side Ethernet interface (10/100MB) for remote control via HTTP (WEB server), SNMP, SMTP and SNTP.

The STS can be directly configured via PC. Furthermore, extensive remote control can be realized.

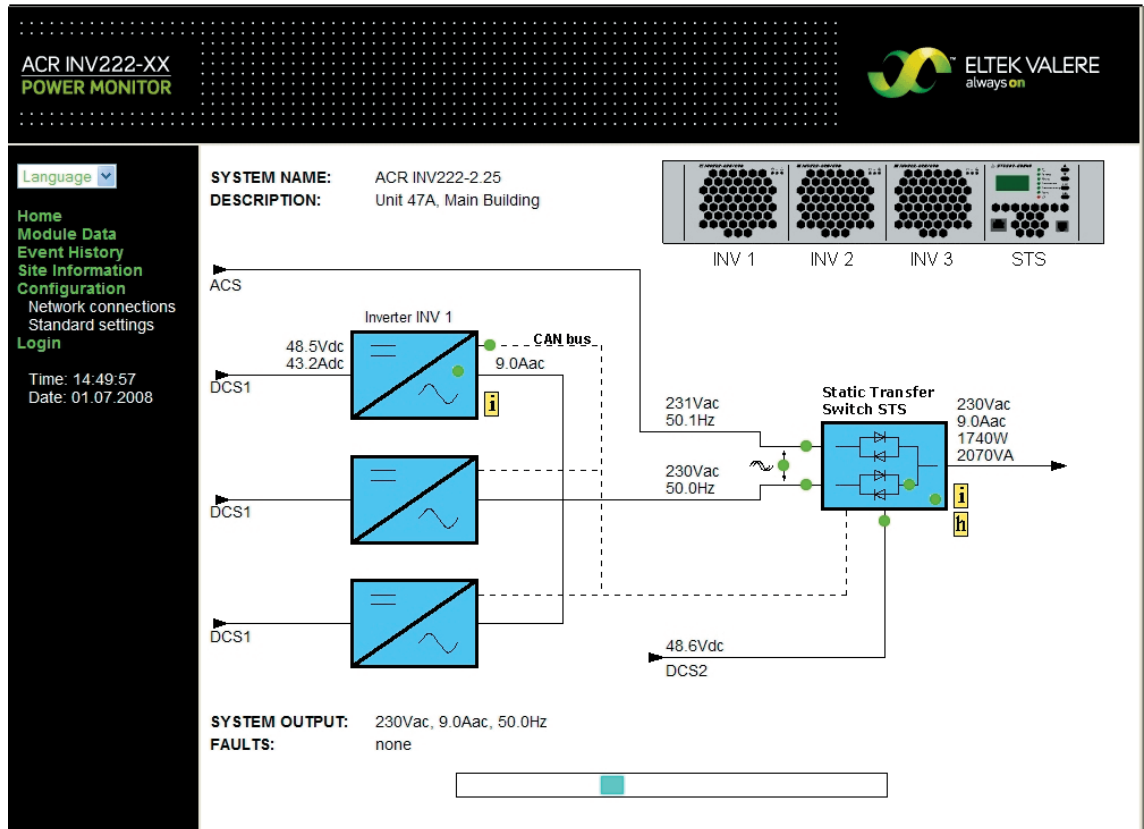

Figure 8. Sample screenshot "Net Connection"

REMARK: A manual for the Net Connection is separately available.

4. Handling

4.1 Storage

The STS must be stored in a dry, dust free environment with a storage temperature according to specific data (see section 8).

4.2 Commissioning

Note: Before commissioning the module, make sure that the battery voltage for the redundant circuitry supply of the STS corresponds to the specification as specified on the type plate.

1. Carefully unpack the unit
2. Put the unit into the provided slot to the right of the sub rack.
3. Carefully slide in the unit until the module connector touched the backplane connector.
4. Increase the force until the unit fits in completely. Avoid using too much force. If the unit does not fit in, begin again at step 2.
5. Secure the module using the captive screw provided with the module.









Caution: After switching off the module the internal capacitors are still fully charged. Do not touch connector pins as they can still be charged with dangerous voltage after disconnection.

4.3 Operation

The operation of the unit takes place with keys located on the front side of the unit. All main functional parameters and measured values are displayed on the front side LCD panel (text indicator) as well as with LED indicators. The different functions are described in the following sections.





4.3.1 LED Indications

Functions of front panel LED indicators

LED		Colour	Main function	Auxiliary function
		green	Unit is ready for operation	
	Inverter	green	Voltage and frequency of source Inverter within permissible limit	Flashing when inverter overload is detected
	Mains	green	Voltage and frequency of source Mains within permissible limit	Flashing when “Load on mains” is activated (see menu 2)
	Load on Inv.	green	Load feeding by source Inverter	
	Load on Mains	green	Load feeding by source Mains	
	Sync.	green	Inverters are synchronized to mains phase and frequency	
		red	Collective Failure (the allocation of the individual trouble codes is programmable)	

4.3.2 Adjustment keys

The adjustment takes place with the four front keys:

Front keys	Function
	<ul style="list-style-type: none"> ➤ during menu item selection: change to previous item (parameter) ➤ during adjustment mode: increase value
	<ul style="list-style-type: none"> ➤ during menu item selection: change to next item (parameter) ➤ during adjustment mode: decrease value
ENT 	<ul style="list-style-type: none"> ➤ enter menu (long pressed) ➤ enter submenu ➤ save parameter and leave submenu
ESC 	<ul style="list-style-type: none"> ➤ leave the menu without changing ➤ enter error list

4.3.3 LC-Display: Indication of measured values and alarm messages

In its initial state, the display shows the measured voltage of the input sources (AC output voltage of inverter, mains voltage) and the STS output current.

Pushing the keys ▲ and ▼ changes between different display topics.

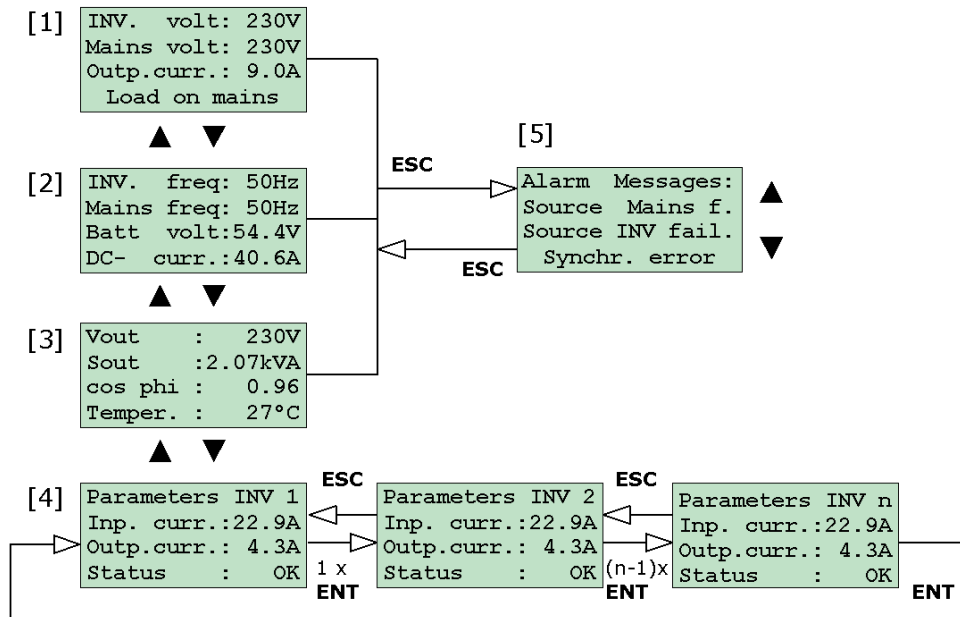

Figure 9. LC-Display: Indication of measured values

The display [1] shows the initial state (basic display). The plain text of the basic display becomes visible after a successful start-up procedure. As shown in figure 9., you can select the displays [1], [2], [3] and [4] by pressing the keys ▲ or ▼:

- If no inverter is registered, display [4] is not available.
- If exactly one inverter is registered, display [4] is visible without inverter number.
- If more than one inverter is registered, it is possible to call the parameters (input current, output current and status) of all connected inverters in succession by pressing “ENT”.
 The inverter number is shown in the first line of the display. Press “ESC” to go one step back.

The display automatically will revert to display [1] if no key is pressed for a period of more than 30 seconds.

Display [5] “Alarm messages” indicates the current alarm status. It can be selected from display [1], [2] and [3] by pressing “ESC”.

By pressing the keys ▲ or ▼ you can scroll through the list of alarm messages if more than three entries are present there. The display “Alarm messages” can be quit by pressing “ESC” again. Basically (factory setting) all individual failures according to “List of the selectable individual alarm messages”, (see section 5.1) are switched “active” and therefore they are visible on the display in case of failure. The alarm messages which shall **not** be visible on the display in case of failure are to be switched “inactive” in the customer menu (see the diagram “customer menu”).

5. Parameter adjustment / Menu structure

In the following sections, the adjustable parameters in the **customer menu** (available for each customer) are described.

REMARK: The configuration of the system during commissioning takes place with the service menu 1 and 2 and the network menu. They are code protected to guard against illegal parameter changes. The special documents only are available for qualified and skilled service personnel.

5.1 Adjustable Parameters (Customer menu)

The following parameters can be adjusted according to the table below:

Customer menu	Functions	Range	Default value
INV-count	Number of connected inverters	0- 16	0
INV-redundancy	Number of redundant inverters	0-15	0
Time/date	Set new time and date	---	---
Configuration CF	Selection (set active/inactive) of single alarm messages for the collective failure (CF) signalization (LED and relay)	All alarm messages*	All active
Delay LED CF	LED time delay of the collective failure signal	1- 60 sec	30
Delay Relay CF	Time delay of the collective failure relay output	1- 60 sec	30
LCD-contrast	Contrast adjustment of the display	0- 100	100
LCD backlight	Background illumination	Not used	On
Language	Selection of the language	english, german, polish, swedish, italian	english

* The following table shows a list of the selectable individual alarm messages:

Alarm messages	Meaning
Source Mains f.	Mains voltage or frequency not Ok
Source INV fail	INV voltage or frequency not Ok
Synchr. error	Mains and INV voltage are not
Inverter fail.	INV failure
INV redundancy	INV failure
INV count crit.	INV failure
STS overtemp	STS over temperature
STS overload	STS output current to high
INV overload	Actual output current exceeds the combined INV power
INV red. overl.	Actual output current exceeds the combined and not redundant INV power
DC-voltage low	Battery voltage low
DC-voltage high	Battery voltage high
fan error	Internal fan error
Uout error	Output voltage < 95% Vin (Mains/INV)
Ubatt< warning	Battery voltage < warning level
Ubatt> warning	Battery voltage > warning level

Continuation of the previous page:

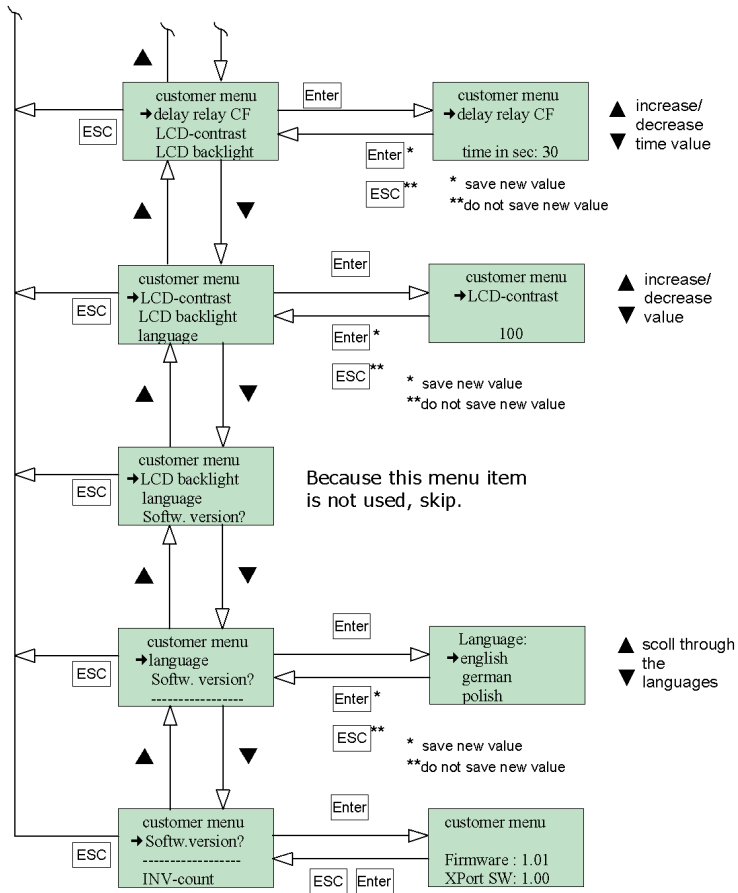

Figure 11. Continuation of the customer menu

The final display shows the currently used Firmware version.

6. Maintenance

In general, the static transfer switch STS is maintenance-free.
A yearly inspection with following checks is recommended:

- Correct fan operation
- Mechanical inspection
- Removal of dust and dirt, especially on radiator surfaces
- Check for internal dust or humidity

Attention! Dust combined with moisture or water may influence or destroy the internal electronic circuits.

Dust inside the unit can be blown out with dry compressed air.
The intervals between this checks depends on ambient conditions of the installed module.

7. Trouble shooting

If a failure occurs in the system, the LED “Alarm” (bell symbol) is illuminated according to the adjustments in the customer menu, item “Configuration CF” (see section 5.2 “Structure of the customer menu”). The failures are shown in clear text mode on the display “Alarm Messages”.

The display “Alarm Messages” can be entered from the basic display with pressing “ESC”.
With pressing the keys ▲ or ▼ you can scroll through the list of alarm messages if more than three entries are present there. The display “Alarm Messages” can be quit by pressing “ESC” again.

Basic display

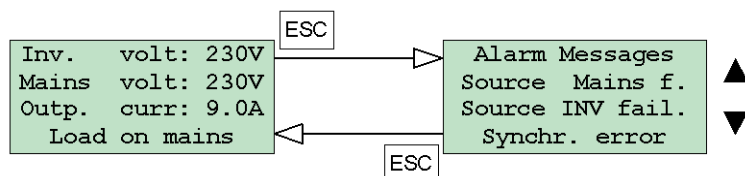

Figure 12. Display “Alarm Messages”

In the table on the following page all possible alarm messages are listed and described.

Static Transfer Switch

STS207

User Manual
Page 22 (28)

List of the possible alarm messages:

Alarm messages	Meaning/possible reason	Corrective action
Source Mains f.	Mains voltage or frequency not Ok	Check mains voltage
Source INV fail	INV voltage or frequency not Ok	Check INV voltage
Synchr. error	Mains and INV voltage are not synchronous	No mains voltage or frequency of mains voltage is not stable.
Inverter fail.	INV failure	CAN communication with one ore more INVs failed or INV failure detected via CAN
INV redundancy	INV failure	The last redundant INV is not Ok! e.g. INV count=3, INV red. count=2 → error active when two inverters are not OK!
INV count crit.	INV failure	The first not redundant INV is not Ok! e.g. INV count=3, INV red. count=2 → error active when three inverters are not OK!
STS overtemp	STS over temperature	Check the air flow Check admissible ambient temperature
STS overload	STS output current to high	Reduce load current
INV overload	Actual output current exceeds the combined INV power#	Reduce load current or increase INV power by additional inverter
INV red. overl.	Actual output current exceeds the combined and not redundant INV power##	Reduce load current or increase INV power by additional inverter
DC-voltage low	Battery voltage low	Check DC voltage system (CAN-Off command is send to the inverters)
DC-voltage high	Battery voltage high	Check DC voltage system (CAN-Off command is send to the inverters)
fan error	Internal fan error	Check air flow, change fan
Uout error	Output voltage < 95% Vin (Mains/INV)	Check output voltage
Ubatt< warning	Battery voltage < warning level	Check DC voltage system
Ubatt> warning	Battery voltage > warning level	Check DC voltage system

#Example: Case 1): The STS is running on Mains with an actual load of 3.0kVA. There are two INVs installed in the system, each one with a nominal output power of 2.25kVA but one of the INVs has switched off by over temperature.

>> Even though the STS is measuring the INV voltage and declares "Source INV" as OK, it will not switch back to INV because the actual output current exceeds the power of one INV!

Case 2): The STS is running on "Source INV" while one INV turns off, the STS will activate the "INV overload" error but will switch to "Source mains" not till then "Source INV" is also broken-down!

##Example: The INV rack is running with three INVs (each 2.25kVA) from witch one is configured as redundant. If the STS output power exceeds 4.5kVA the error "INV red. overl." will occur. The system output power is too high for the two not redundant INVs!

8. Technical specifications

Type designation	see section 3
Article code	see section 3
AC input:	
Nominal input voltage source 1	230V _{AC} ±20%
Nominal input voltage source 2	230V _{AC} ±20%
Input frequency	50 Hz/ 60Hz, programmable
Synchronization range	±2Hz
Efficiency	≥ 99%
Mains input fuse	32A semiconductor protection
External mains fuse	recommended: 32A gL or MCB characteristic B
DC Voltage input:	
Redundant circuitry supply	see section 3
AC Output:	
Nominal output voltage	230V _{AC} , voltage range acc. to input values, switch over threshold ±5 to ±20% programmable
Nominal output current	30.4A _{AC}
Nominal switching capacity	7kVA
Overload capability	1000% for 10 ms (fuse tripping of 32A is guaranteed)
Output frequency	acc. to the input frequency
Transfer time	≤4ms
Other specifications:	
Monitoring functions	voltage/frequency of sources Mains and INV; synchronization mains- inverter; over temperature; CAN communication lost; synchronization bus interrupted
LED signalling	Operation (green), source Mains OK (green), source INV OK (green), load on inverter (green), load on mains (green), synchronization (green), collective failure (red)
Configuration	with front side operation keys UP/DOWN/ENTER/ESC and LCD (4 x 16 characters) or via Ethernet (internal WEB server)
Fault signalization	text message on LCD, in addition 1 programmable isolated collective failure (alarm) relay output; Email or SNMP (Trap) notification
Rated contact load of the alarm relay	Max. switching power 62.5VA; 30W Max. switching voltage 125V _{AC} ; 60V _{DC}

Static Transfer Switch STS207

User Manual

Page 24 (28)



Communications interface	CAN-Bus, proprietary protocol; redundant synchronization bus; Ethernet 10/100MB Half/Full (WEB server, SNMP, SMTP, SNTP)
Ambient temperature	operation: -20°C to +55°C; storage: -40°C to + 85°C
Cooling	fan cooling (temperature regulated; monitored)
Max. installation altitude	≤1500m
Audible noise	≤45dBA
Type of construction	1/4 x19", 2U
Surfaces	powder coating RAL 7035 (front panel only) with black imprint; constructive parts: anodized metal
Dimensions (W/H/D)	106.4/88.4/335 mm
Minimum installation depth	400mm (in combination with an assembly set 19" sub rack)
Weight	approx. 2.2 kg
Connectors	Rear: AC inputs/output, DC input and signalization (DIN 41612-M-connector); Front: Ethernet (RJ45), CAN (RJ11)

Applicable standards:

Mechanical construction	acc. to VDE 0160 edition 5.88 chapter 7.2.2
Protection class	IP20
Climatic conditions	acc. to IEC 721-3-3 class 3K3/3Z1/3B1/3C2/3S2/3M2
RFI suppression / immunity	CE- label; ((EN50081-1; EN55011/55022 class "B"; EN50082-2; EN61000-4 part 2/3/4/5)
Compliance to safety standards	acc. to EN60950-1; VDO0100 T410; VDO0110; EN60146

8.1 Dimensional drawings

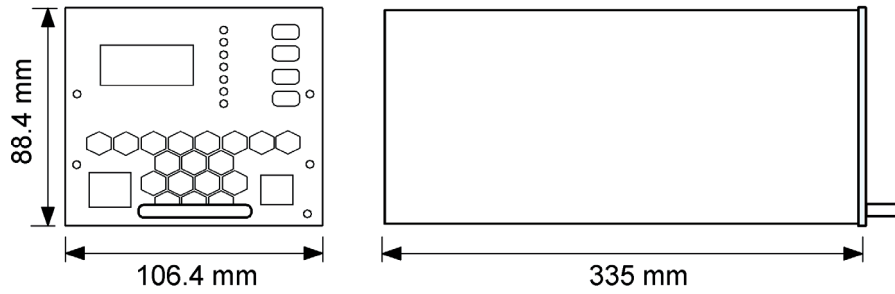

Figure 13. Module dimensions



Supplier:

	ELTEK VALERE INDUSTRIAL GmbH Schillerstraße 16 D-32052 Herford
	+ 49 (0) 5221 1708-210
FAX	+ 49 (0) 5221 1708-222
Email	Info.industrial@eltekvalere.com
Internet	http://www.eltekvalere-industrial.com